

# FH1510G

## N-Channel Enhancement Mode Power MOSFET

### Description

The FH1510G uses advanced trench technology and design to provide excellent  $R_{DS(ON)}$  with low gate charge. It can be used in a wide variety of applications.

### Applications

- Power Management in Telecom., Industrial Automation, CE
- Current Switching in DC/DC & AC/DC Sub-systems
- Motor Driving in Power Tool, E-vehicle, Robotics

### Product Summary

Parameter	Typ.	Unit
$V_{DS}$	100	V
$V_{GS(th)}$	1.8	V
$I_D$ (@ $V_{GS} = 10V$ )	50	A
$R_{DS(ON)}$ (@ $V_{GS} = 10V$ )	10	m $\Omega$ (MAX)
$R_{DS(ON)}$ (@ $V_{GS} = 4.5V$ )	13	m $\Omega$ (MAX)

- Ultra-low  $R_{DS(ON)}$
- Low Gate Charge
- High Current Capability
- 100% UIS Tested, 100%  $R_{\theta}$  Tested

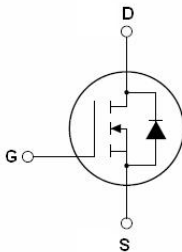

Schematic dia Gram



Marking and pin Assignment

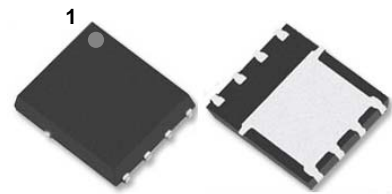

PDFN5x6-8L top and bottom view

## Limiting Values

ymbol	Parameter	Conditions	Min	Max	Unit
$V_{DS}$	Drain-Source Voltage	$T_C = 25\text{ }^\circ\text{C}$	100		V
$V_{GS}$	Gate-Source Voltage	$T_C = 25\text{ }^\circ\text{C}$	-	$\pm 20$	V
$I_D^*$	Drain Current ( DC )	$T_C = 25\text{ }^\circ\text{C}$ , $V_{GS} = 10\text{ V}$	-	50	A
$I_{DM}^{***, ***}$	Drain Current ( Pulsed )	$T_C = 25\text{ }^\circ\text{C}$ , $V_{GS} = 10\text{ V}$	-	158	A
$P_{tot}^*$	Total Power Dissipation	$T_C = 25\text{ }^\circ\text{C}$	-	48	W
$T_{stg}$	Storage Temperature		- 55	150	$^\circ\text{C}$
$T_J$	Junction Temperature		-	150	$^\circ\text{C}$
$I_S$	Diode Forward Current	$T_C = 25\text{ }^\circ\text{C}$	-	20	A
$E_{AS}^*$	Single Pulsed Avalanche Energy	$V_{DD} = 50\text{ V}$ , $L = 0.5\text{ mH}$	-	60	mJ
$R_{\theta JA}^*$	Thermal Resistance- Junction to Ambient		-	71	$^\circ\text{C} / \text{W}$
$R_{\theta JC}^*$	Thermal Resistance- Junction to Case		-	4.5	

Notes :

\* Surface Mounted on 1 in<sup>2</sup> pad area,  $t \leq 10\text{ sec}$

\*\* Pulse width  $\leq 300\text{ }\mu\text{s}$ , duty cycle  $\leq 2\%$

\*\*\* limited by bonding wire

## Electrical Characteristics (T<sub>A</sub> = 25 °C Unless Otherwise Noted)

Symbol	Parameter	Conditions	Min	Typ	Max	Unit
<b>Static Characteristics</b>						
BV <sub>DSS</sub>	Drain-Source Breakdown Voltage	V <sub>GS</sub> = 0 V, I <sub>D</sub> = 250 μA	100	-	-	V
V <sub>GS(th)</sub>	Gate Threshold Voltage	V <sub>DS</sub> = V <sub>GS</sub> , I <sub>DS</sub> = 250 μA	1.5	1.8	2.5	V
I <sub>DSS</sub>	Zero Gate Voltage Source Current	V <sub>DS</sub> = 90, V <sub>GS</sub> = 0 V	-	-	1	μA
I <sub>GSS</sub>	Gate Leakage Current	V <sub>GS</sub> = ± 20 V, V <sub>DS</sub> = 0 V	-	-	± 100	nA
R <sub>DS(on)</sub> <sup>a</sup>	Drain-Source On-State Resistance	V <sub>GS</sub> = 10 V, I <sub>D</sub> = 20A	-	8.2	10	mΩ
		V <sub>GS</sub> = 4.5 V, I <sub>D</sub> = 10A	-	9.5	13	
<b>Diode Characteristics</b>						
V <sub>SD</sub> <sup>a</sup>	Diode Forward Voltage	I <sub>SD</sub> = 20 A, V <sub>GS</sub> = 0 V	-	0.86	1.0	V
t <sub>rr</sub>	Reverse Recovery Time	I <sub>SD</sub> = 20 A, dI <sub>SD</sub> /dt = 100 A/μs	-	50.7	-	nS
Q <sub>rr</sub>	Reverse Recovery Charge		-	72.5	-	nC
<b>Dynamic Characteristics<sup>b</sup></b>						
C <sub>iss</sub>	Input Capacitance	V <sub>GS</sub> = 0 V, V <sub>DS</sub> = 50 V Frequency = 1 MHz	-	2131	-	pF
C <sub>oss</sub>	Output Capacitance		-	606	-	
C <sub>rss</sub>	Reverse Transfer Capacitance		-	21	-	
t <sub>d(on)</sub>	Turn-on Delay Time	V <sub>DS</sub> = 50 V, V <sub>GEN</sub> = 10 V, R <sub>G</sub> = 3.9 Ω, R <sub>L</sub> = 2.5 Ω, I <sub>D</sub> = 20 A	-	17	-	nS
t <sub>r</sub>	Turn-on Rise Time		-	4	-	
t <sub>d(off)</sub>	Turn-off Delay Time		-	32	-	
t <sub>f</sub>	Turn-off Fall Time		-	8	-	
<b>Gate Charge Characteristics<sup>b</sup></b>						
Q <sub>g</sub>	Total Gate Charge	V <sub>GS</sub> = 10 V, V <sub>DS</sub> = 50 V, I <sub>DS</sub> = 20 A	-	29.4	-	nC
Q <sub>gs</sub>	Gate-Source Charge		-	9	-	
Q <sub>gd</sub>	Gate-Drain Charge		-	5	-	

Notes :

- a : Pulse test ; pulse width ≤ 300 μs, duty cycle ≤ 2 %
- b : Guaranteed by design, not subject to production testing
- c: NHCX defines “ Green ” as lead-free ( RoHS compliant ) and halogen free ( Br or Cl does not exceed 900 ppm by weight in homogeneous material and total of Br and Cl does not exceed 1500 ppm by weight; Follow IEC 61249-2-21 and IPC / JEDEC J-STD-020C )

# Typical Characteristics (Cont.)

### Power Capability

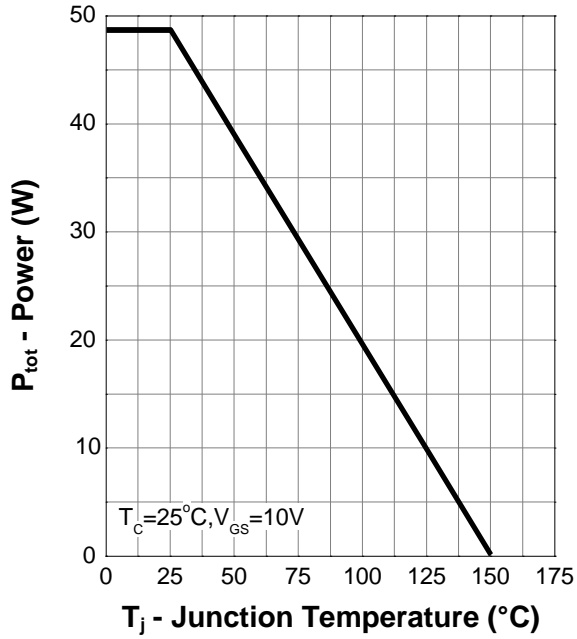

### Current Capability

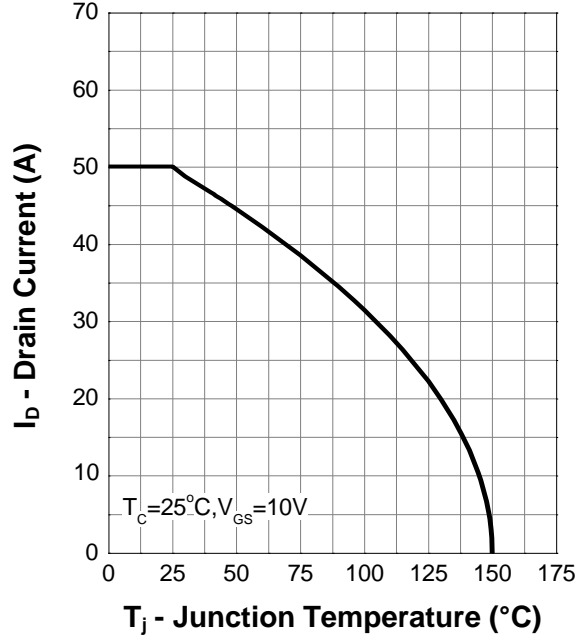

### Safe Operation. a

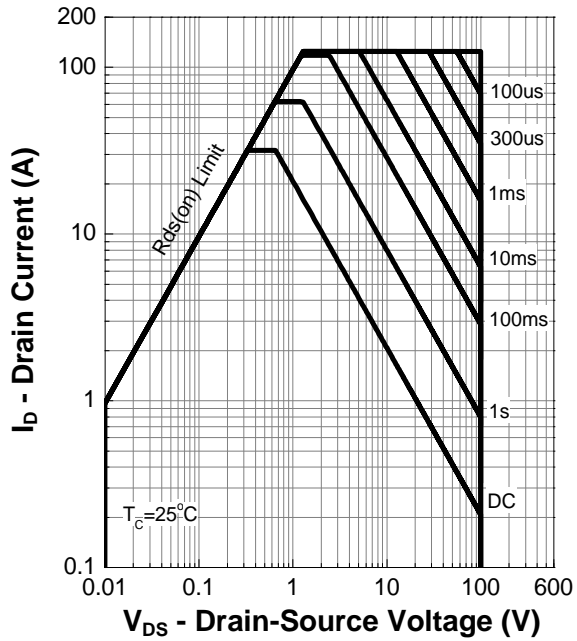

### Transient Thermal Impedance

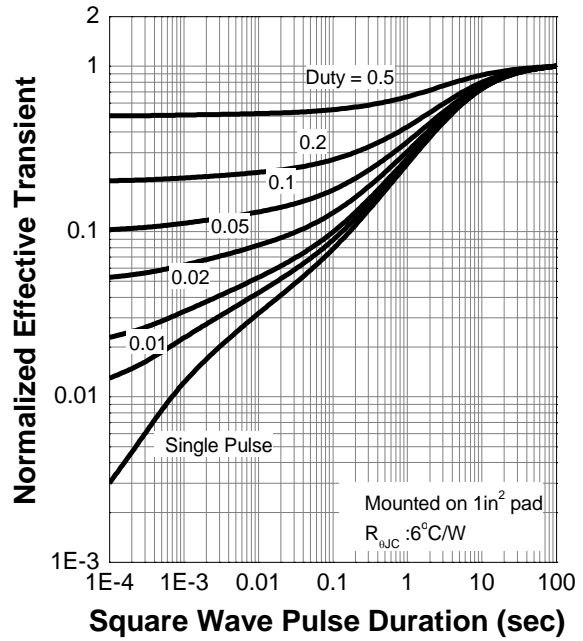

## Typical C haracteristics (Cont.)

### Output Characteristics

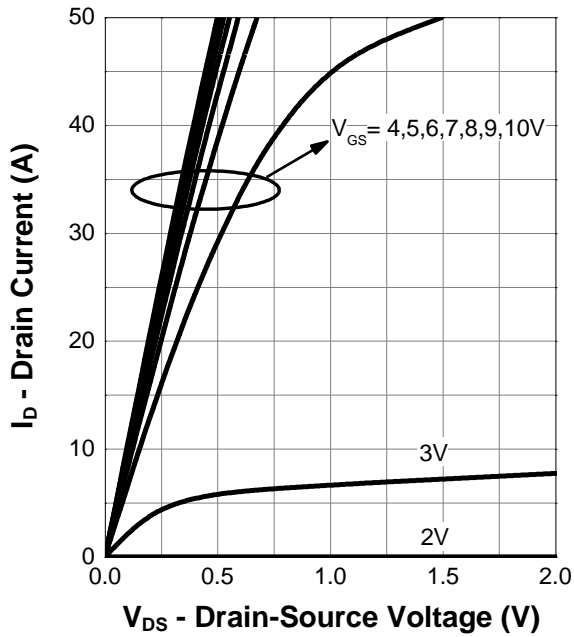

### On Resistance

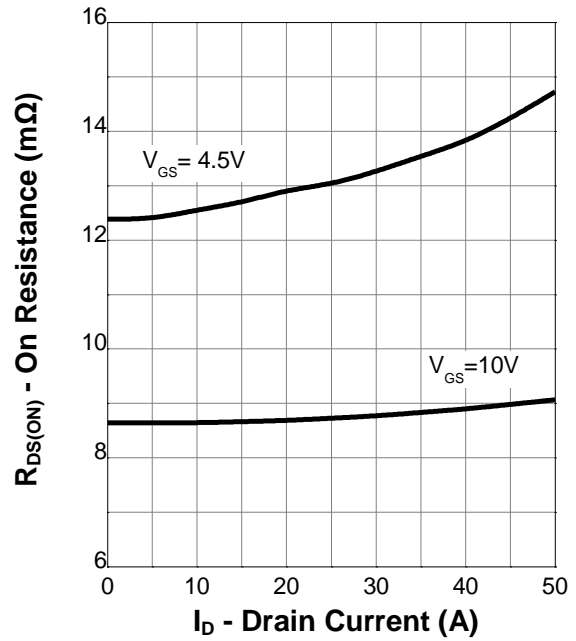

### Transfer Characteristics

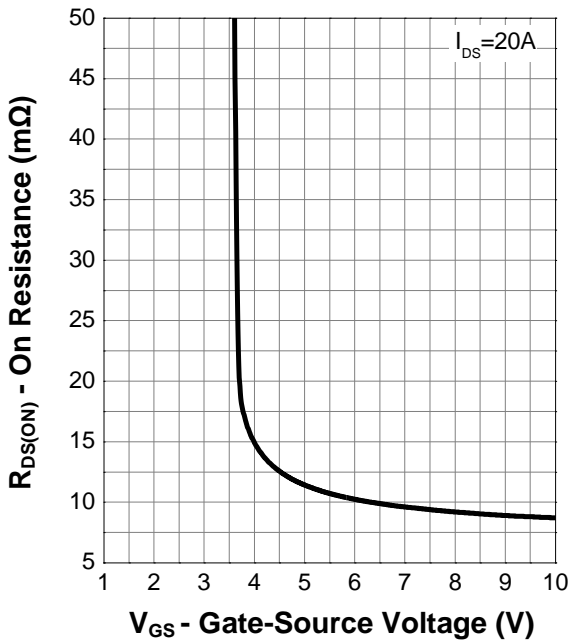

### Normalized Threshold Voltage

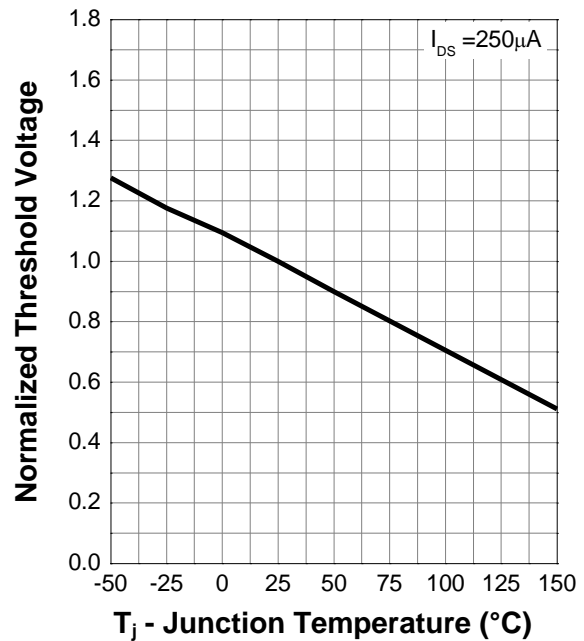

## 7. Typical Characteristics (Cont.)

Normalized On Resistance

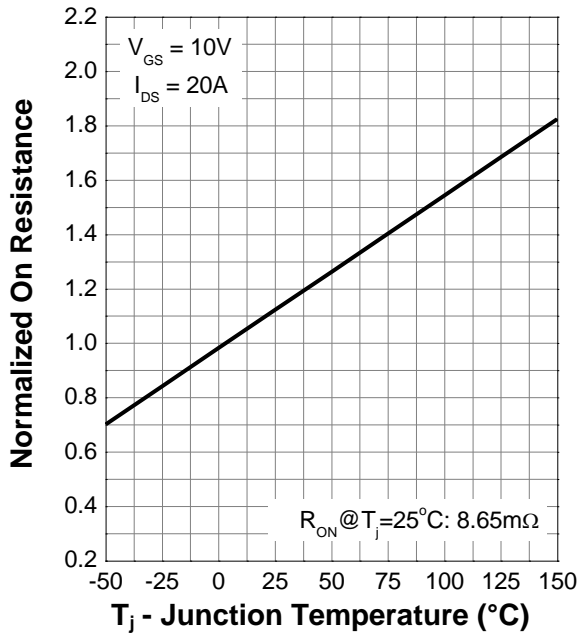

Diode Forward Current

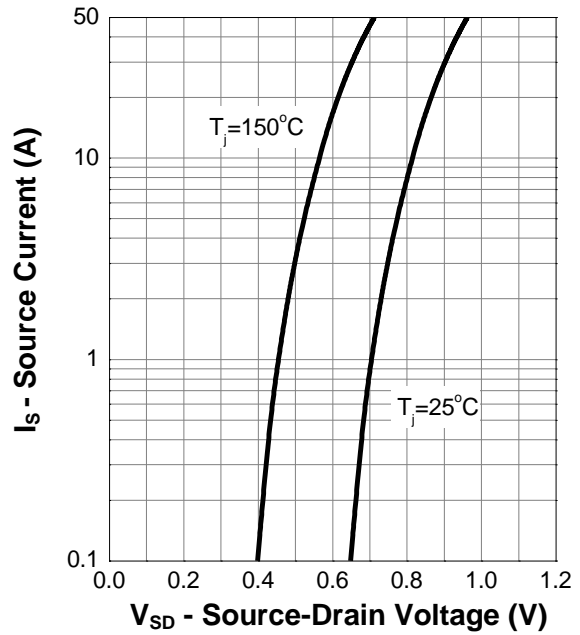

Capacitance

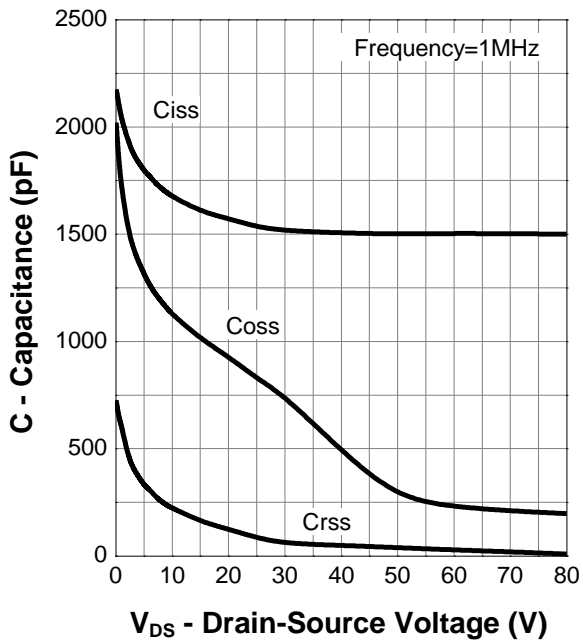

Gate Charge

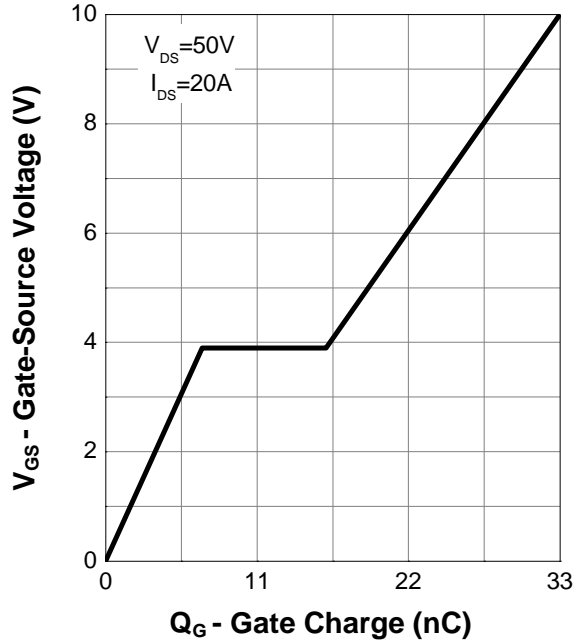

## Package Information : PDFN5x6-8L

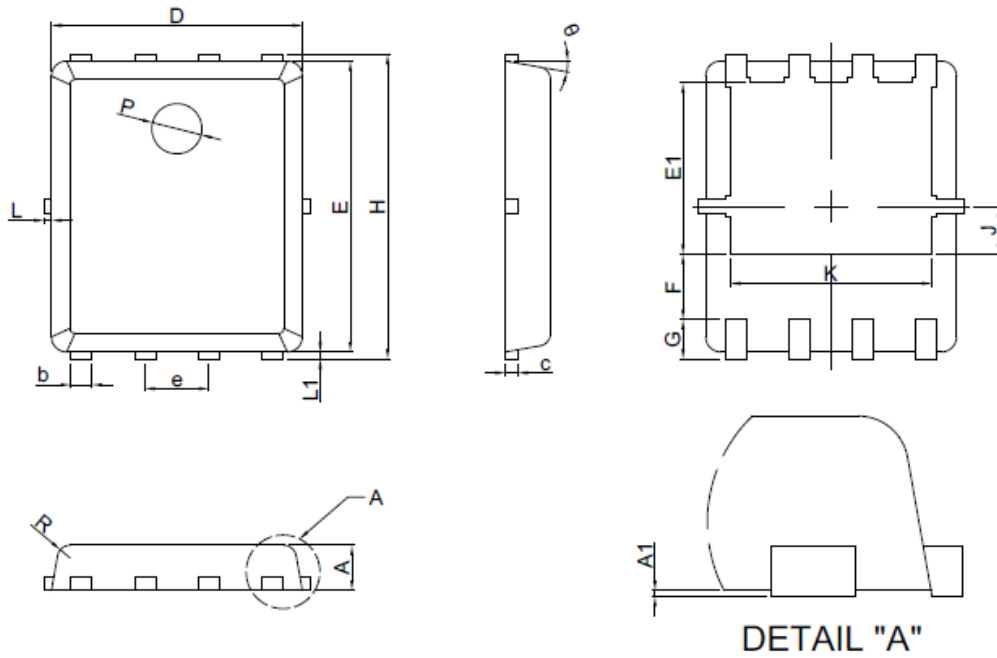

Symbol	Dimensions In Millimeters	
	MIN.	MAX.
A	0.80	1.00
A1	0.00	0.05
b	0.35	0.49
c	0.254REF	
D	4.80	5.20
F	1.40REF	
E	5.60	5.90
e	1.27BSC	
H	5.80	6.20
L1	0.10	0.18
G	0.60REF	
K	4.00REF	
L	-	0.15
J	0.95BSC	
P	1.00REF	
E1	3.40REF	
θ	6°	14°
R	0.25REF	