

FH3510P

N-Channel Enhancement Mode MOSFET

Features

- SGT Trench Technology
- Low $R_{DS(ON)}$, Low Gate Charge
- Fast Switching
- Excellent Avalanche Characteristics
- 100% UIS Tested, 100% R_g Tested
- High Current Capability

Product Summary

Parameter	Typ.	Unit
V_{DS}	100	V
I_D (@ $V_{GS} = 10V$) ⁽¹⁾	150	A
$R_{DS(ON)}$ (@ $V_{GS} = 10V$) (Typ)	2.8	$m\Omega$
$R_{DS(ON)}$ (@ $V_{GS} = 4.5V$) (Typ)	3.4	$m\Omega$

Application

- Motor Control and Drive
- Uninterruptible Power Supply (UPS)
- Battery Management

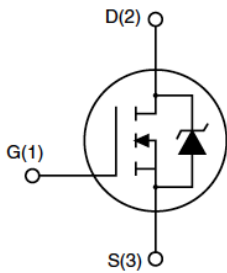

Schematic diagram

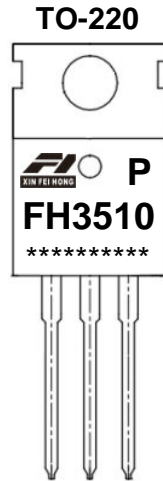

Marking and pin assignment

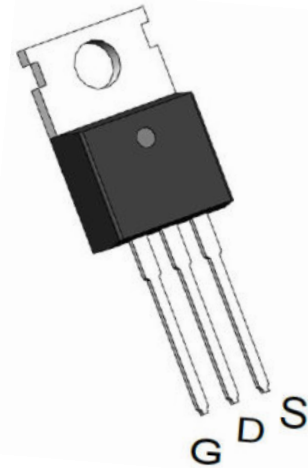

TO-220 top view

Absolute Maximum Ratings (T_c=25°C unless otherwise specified)

Symbol	Parameter	Max.	Units
V_{DSS}	Drain-Source Voltage	100	V
V_{GSS}	Gate-Source Voltage	±20	V
I_D	Continuous Drain Current ⁽¹⁾	T _c = 25°C	150
		T _c = 100°C	95
I_{DM}	Pulsed Drain Current ⁽²⁾	465	A
I_{AS}	Avalanche Current ⁽³⁾	72	A
E_{AS}	Single Pulsed Avalanche Energy ⁽³⁾	262	mJ
P_D	Power Dissipation ⁽⁴⁾	194	W
$R_{\theta JC}$	Thermal Resistance, Junction to Case	0.63	°C/W
$R_{\theta JA}$	Thermal Resistance, Junction to Ambient	58	°C/W
T _J , T _{STG}	Operating and Storage Temperature Range	-55 to +150	°C

Electrical Characteristics (@ $T_J = 25^\circ\text{C}$ unless otherwise specified)

Parameter	Symbol	Conditions	Min.	Typ.	Max.	Unit
STATIC PARAMETERS						
Drain-Source Breakdown Voltage	$V_{(BR)DSS}$	$I_D = 250\mu\text{A}, V_{GS} = 0\text{V}$	100	105		V
Zero Gate Voltage Drain Current	I_{DSS}	$V_{DS} = 80\text{V}, V_{GS} = 0\text{V}$ $T_J = 55^\circ\text{C}$			1.0 5.0	μA
Gate-Body Leakage Current	I_{GSS}	$V_{DS} = 0\text{V}, V_{GS} = \pm 20\text{V}$			± 100	nA
Gate Threshold Voltage	$V_{GS(th)}$	$V_{DS} = V_{GS}, I_D = 250\mu\text{A}$	1.2	1.6	2.5	V
Static Drain-Source ON-Resistance	$R_{DS(on)}$	$V_{GS} = 10\text{V}, I_D = 20\text{A}$		2.8	3.4	$\text{m}\Omega$
Static Drain-Source ON-Resistance	$R_{DS(on)}$	$V_{GS} = 4.5\text{V}, I_D = 15\text{A}$		3.4	4.3	$\text{m}\Omega$
Forward Transconductance	g_{FS}	$V_{DS} = 5\text{V}, I_D = 20\text{A}$		109		S
Diode Forward Voltage	V_{SD}	$I_S = 1\text{A}, V_{GS} = 0\text{V}$		0.7	1.0	V
Diode Continuous Current	I_S	$T_C = 25^\circ\text{C}$			114	A
DYNAMIC PARAMETERS ⁽⁵⁾						
Input Capacitance	C_{iss}	$V_{GS} = 0\text{V}, V_{DS} = 50\text{V}, f = 1\text{MHz}$		4646		pF
Output Capacitance	C_{oss}			1214		pF
Reverse Transfer Capacitance	C_{rss}			5.8		pF
Gate Resistance	R_g	$V_{GS} = 0\text{V}, V_{DS} = 0\text{V}, f = 1\text{MHz}$		2.3		Ω
SWITCHING PARAMETERS ⁽⁵⁾						
Total Gate Charge (@ $V_{GS} = 10\text{V}$)	Q_g	$V_{GS} = 0 \text{ to } 10\text{V}$ $V_{DS} = 50\text{V}, I_D = 20\text{A}$		78		nC
Total Gate Charge (@ $V_{GS} = 6.0\text{V}$)	Q_g			56		nC
Gate Source Charge	Q_{gs}			11.2		nC
Gate Drain Charge	Q_{gd}			26		nC
Turn-On Delay Time	$t_{D(on)}$	$V_{GS} = 10\text{V}, V_{DS} = 50\text{V}$ $R_L = 2.5\Omega, R_{GEN} = 6\Omega$		10.0		ns
Turn-On Rise Time	t_r			22		ns
Turn-Off Delay Time	$t_{D(off)}$			84		ns
Turn-Off Fall Time	t_f			61		ns
Body Diode Reverse Recovery Time	t_{rr}		$I_F = 20\text{A}, dI_F/dt = 100\text{A}/\mu\text{s}$		84	
Body Diode Reverse Recovery Charge	Q_{rr}	$I_F = 20\text{A}, dI_F/dt = 100\text{A}/\mu\text{s}$		216		nC

Notes:

1. Computed continuous current assumes the condition of T_{J_Max} while the actual continuous current depends on the thermal & electro-mechanical application board design.
2. This single-pulse measurement was taken under $T_{J_Max} = 150^\circ\text{C}$.
3. This single-pulse measurement was taken under the following condition [$L = 0.1\text{mH}, V_{GS} = 10\text{V}, V_{DS} = 50\text{V}$] while its value is limited by $T_{J_Max} = 150^\circ\text{C}$.
4. The power dissipation P_D is based on $T_{J_Max} = 150^\circ\text{C}$.
5. This value is guaranteed by design hence it is not included in the production test.
6. Continuous current rating is limited by the package used.

Typical Electrical & Thermal Characteristics

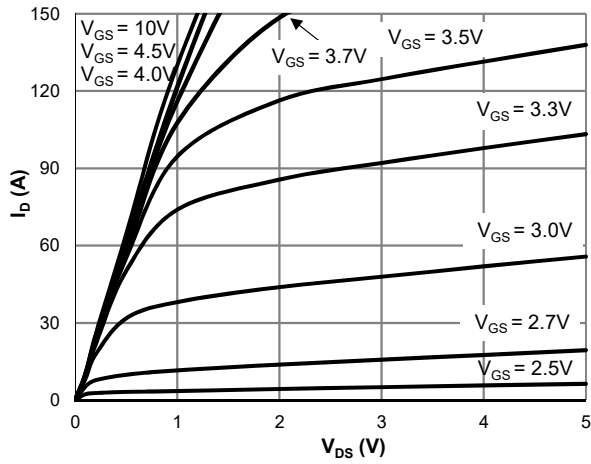

Figure 1: Saturation Characteristics

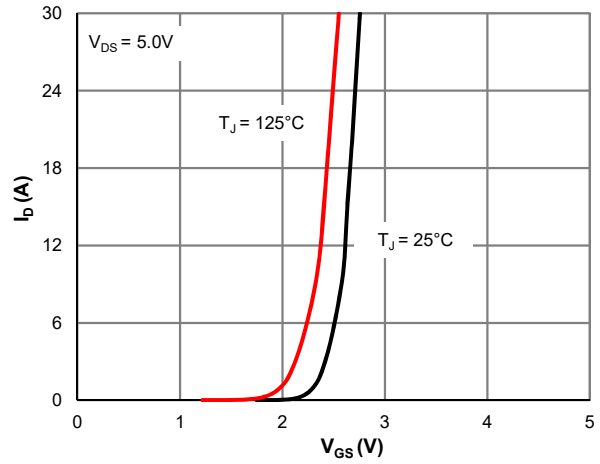

Figure 2: Transfer Characteristics

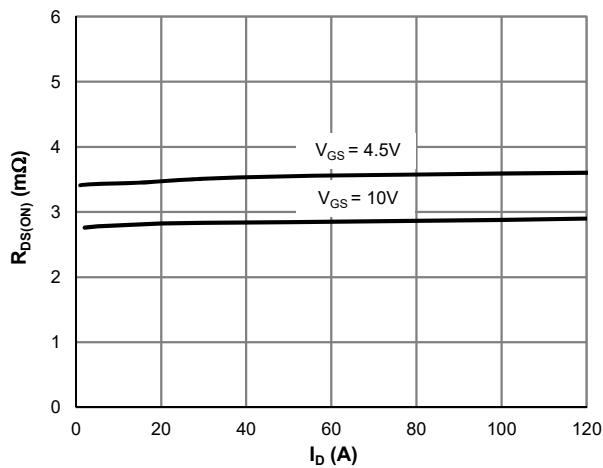

Figure 3: $R_{DS(ON)}$ vs. Drain Current

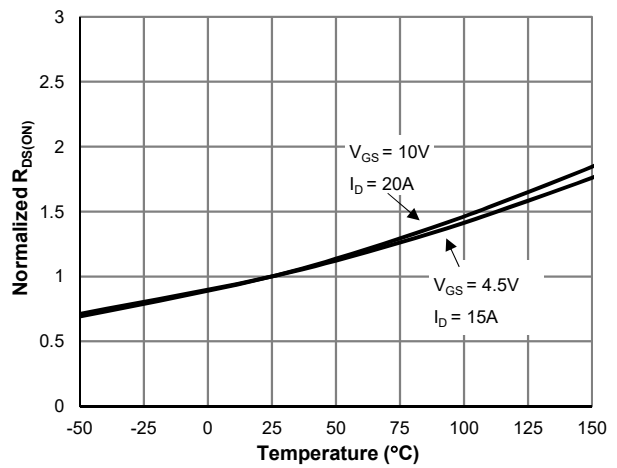

Figure 4: $R_{DS(ON)}$ vs. Junction Temperature

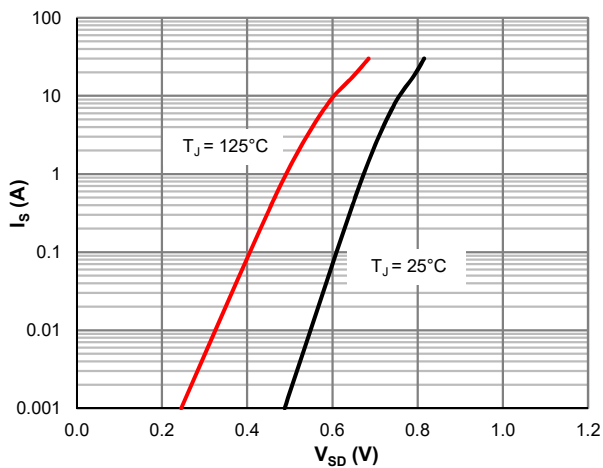

Figure 5: Body-Diode Characteristics

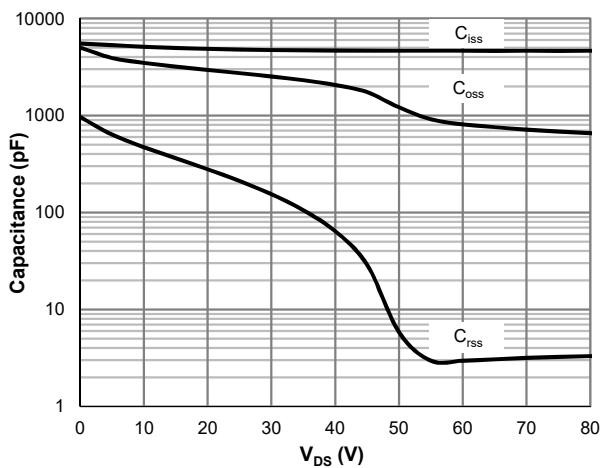

Figure 6: Capacitance Characteristics

Typical Electrical & Thermal Characteristics

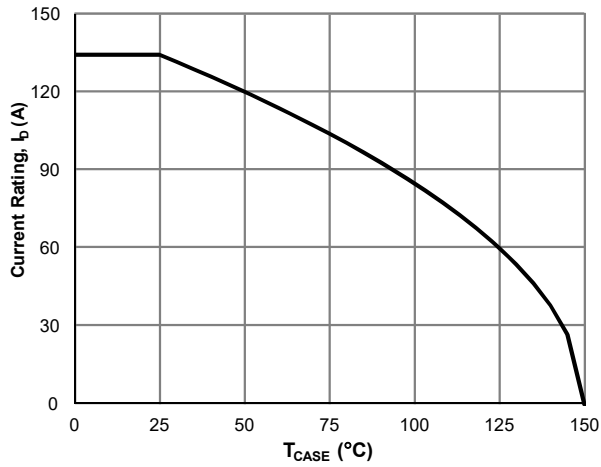

Figure 7: Current De-rating

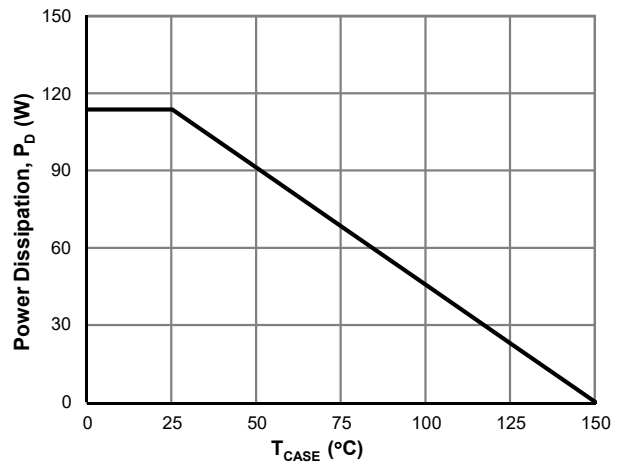

Figure 8: Power De-rating

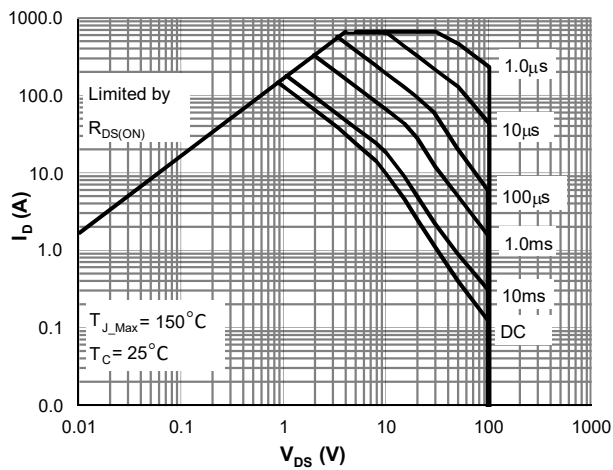

Figure 9: Maximum Safe Operating

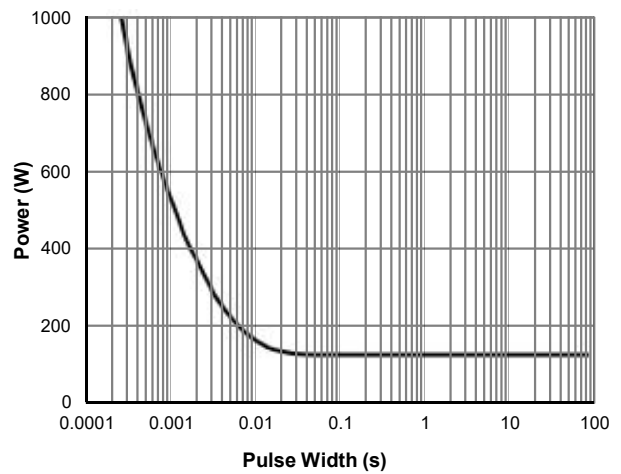
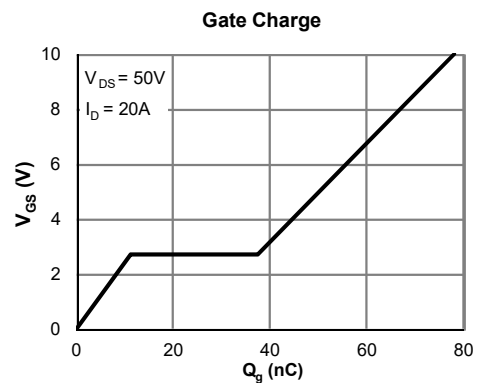
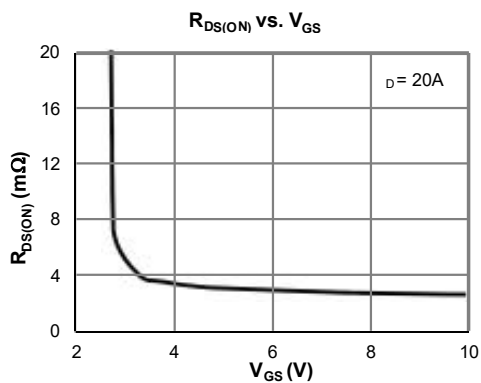

Figure 10: Single Pulse Power Rating, Junction-to-Case



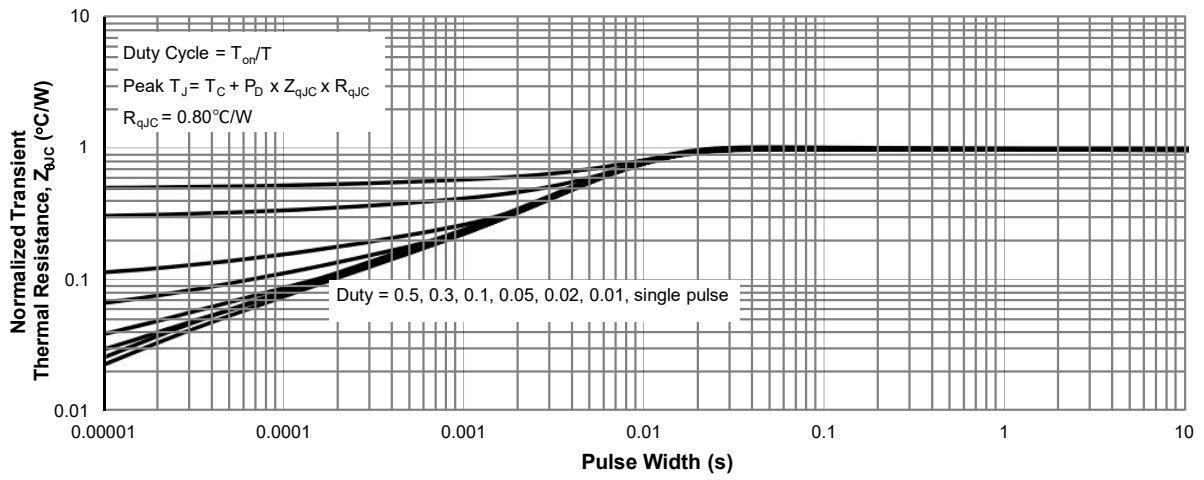
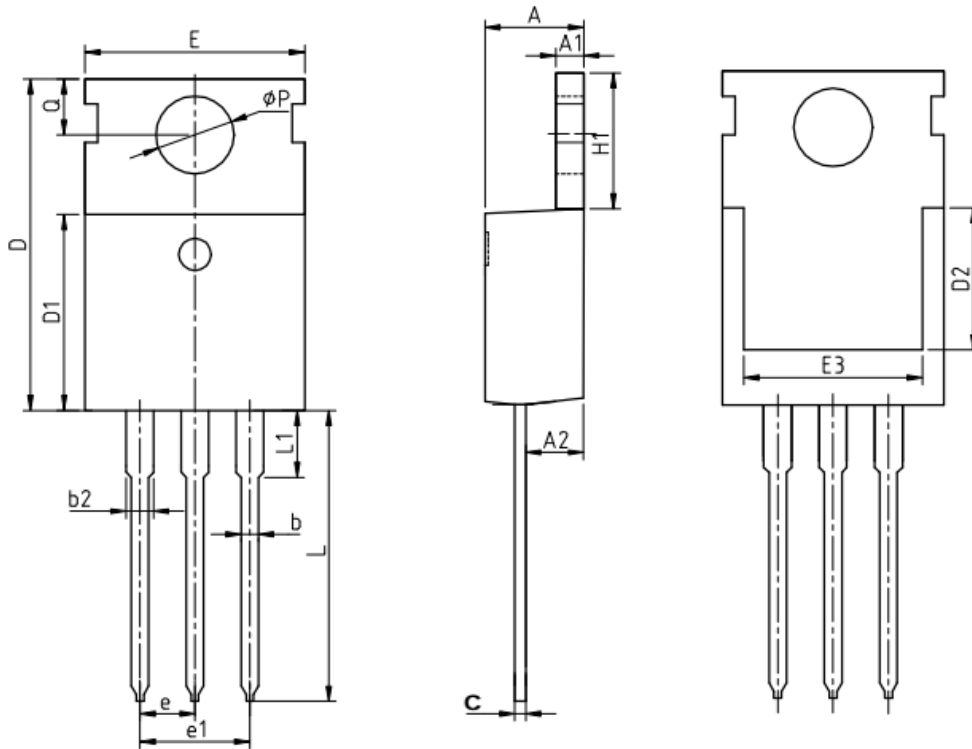

Figure 11: Normalized Maximum Transient Thermal Impedance

Package Information : TO-220



COMMON DIMENSIONS

SYMBOL	mm		
	MIN	NOM	MAX
A	4.37	4.57	4.77
A1	1.15	1.30	1.45
A2	2.20	2.40	2.60
b	0.70	0.80	0.95
b2	1.17	1.27	1.47
c	0.40	0.50	0.65
D	15.10	15.60	16.10
D1	8.80	9.10	9.40
D2	5.50	-	-
E	9.70	10.00	10.30
E3	7.00	-	-
e	2.54 BSC		
e1	5.08 BSC		
H1	6.25	6.50	6.85
L	12.75	13.50	13.80
L1	-	3.10	3.40
φP	3.40	3.60	3.80
Q	2.60	2.80	3.00