

FH1806D2

N-Channel Trench Power MOSFET

Description

N-Channel Power MOSFET designed by Company, according to the advanced TrenchTechnology. This devices provide an excellent gate charge and $R_{DS(on)}$, which leads to extremely communication and conduction losses. So it is very suitable for AC/DC power conversion, load switch and industrial power applications.

General Features

- $V_{DSS}=60V$, $I_D=80A$
 $R_{DS(ON)}=7.9m\Omega$ (MAX) @ $V_{GS}=10V$
- 100% avalanche tested
- Easy to use/drive
- RoHS compliant

Applications

- DC/DC Converter
- Battery Protection Charge/Discharge
- Load Switch
- Synchronous Rectification



Absolute Maximum Ratings $T_A = 25^\circ C$, unless otherwise noted

Parameter	Symbol	Values	Unit
Drain-Source Voltage ($V_{GS}=0V$)	V_{DS}	60	V
Continuous Drain Current ²⁾	I_D	$T_C = 25^\circ C$	80
		$T_C = 100^\circ C$	51
Pulsed Drain Current ³⁾	$I_{D,pulse}$	320	A
Gate-Source Voltage	V_{GSS}	± 20	V
Single Pulse Avalanche Energy ¹⁾	E_{AS}	244	mJ
Power Dissipation	P_D	83	W
Operating Junction and Storage Temperature Range	T_J, T_{stg}	-55~+150	$^\circ C$
Thermal Resistance, Junction-to-Case	R_{thJC}	1.5 (MAX)	$^\circ C/W$
Thermal Resistance, Junction-to-Ambient	R_{thJA}	62 (MAX)	$^\circ C/W$

Notes

- 1) $L=0.5mH$, $V_{DD}=30V$, Start $T_J=25^\circ C$.
- 2) Limited by maximum junction temperature.
- 3) Repetitive Rating: Pulse width limited by maximum junction temperature.

Electrical Characteristics $T_J = 25^\circ\text{C}$, unless otherwise noted						
Parameter	Symbol	Test Conditions	Value			Unit
			Min.	Typ.	Max.	
Static Characteristics						
Drain-Source Breakdown Voltage	$V_{(BR)DSS}$	$V_{GS} = 0V, I_D = 250\mu\text{A}$	60	66	--	V
Zero Gate Voltage Drain Current	I_{DSS}	$V_{DS} = 60V$ $V_{GS} = 0V, T_J = 25^\circ\text{C}$	--	--	1	μA
		$V_{DS} = 60V$ $V_{GS} = 0V, T_J = 125^\circ\text{C}$	--	--	100	
Gate-Source Leakage Current	I_{GSS}	$V_{GS} = \pm 20V$	--	--	± 100	nA
Gate-Source Threshold Voltage	$V_{GS(th)}$	$V_{DS} = V_{GS}, I_D = 250\mu\text{A}$	2	2.8	4	V
Drain-Source On-State-Resistance	$R_{DS(on)}$	$V_{GS} = 10V, I_D = 20A$	--	6.5	7.9	$\text{m}\Omega$
Gate Resistance	R_G	$f = 1.0\text{MHz}$ open drain	--	1.6	--	Ω
Dynamic Characteristics						
Input Capacitance	C_{iss}	$V_{GS} = 0V, V_{DS} = 30V$ $f = 1.0\text{MHz}$	--	4009	--	pF
Output Capacitance	C_{oss}		--	243	--	
Reverse Transfer Capacitance	C_{rss}		--	201	--	
Total Gate Charge	Q_g	$V_{DS} = 30V, I_D = 20A$ $V_{GS} = 10V$	--	76	--	nC
Gate-Source Charge	Q_{gs}		--	17	--	
Gate-Drain Charge	Q_{gd}		--	19	--	
Gate Plateau Voltage	$V_{plateau}$		--	4.3	--	V
Turn-on Delay Time	$t_{d(on)}$	$V_{DS} = 30V, V_{GS} = 10V$ $R_G = 3\Omega, I_D = 20A$	--	19	--	ns
Turn-on Rise Time	t_r		--	42	--	
Turn-off Delay Time	$t_{d(off)}$		--	48	--	
Turn-off Fall Time	t_f		--	29	--	
Drain-Source Body Diode Characteristics						
Body Diode Forward Voltage	V_{SD}	$T_J = 25^\circ\text{C}, I_{SD} = 20A$ $V_{GS} = 0V$	--	--	1.2	V
Continuous Diode Forward Current	I_S		--	--	80	A
Reverse Recovery Time	t_{rr}	$I_F = 20A, di_F/dt = 100A/\mu\text{s}$	--	28	--	ns
Reverse Recovery Charge	Q_{rr}		--	52	--	nC

Typical Characteristics $T_J = 25^\circ\text{C}$, unless otherwise noted

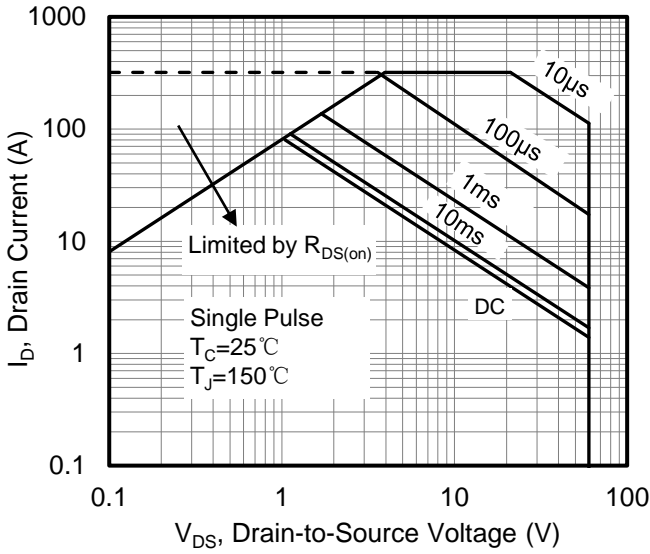

Figure 1. Maximum Safe Operating Area

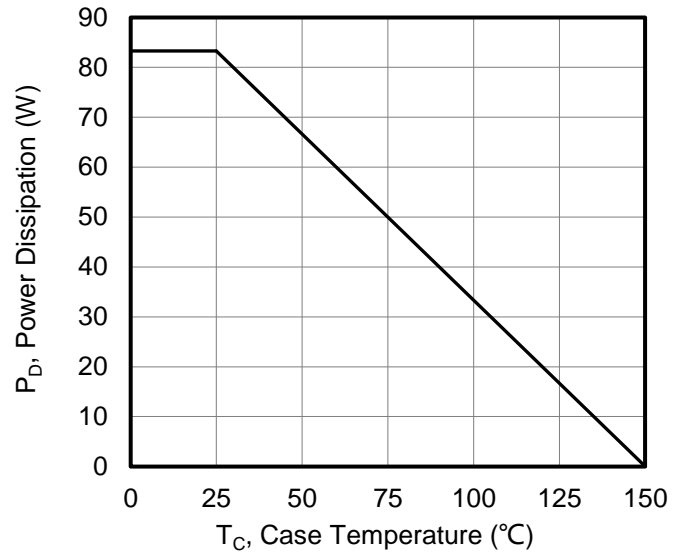

Figure 2. Maximum Power Dissipation vs Case Temperature

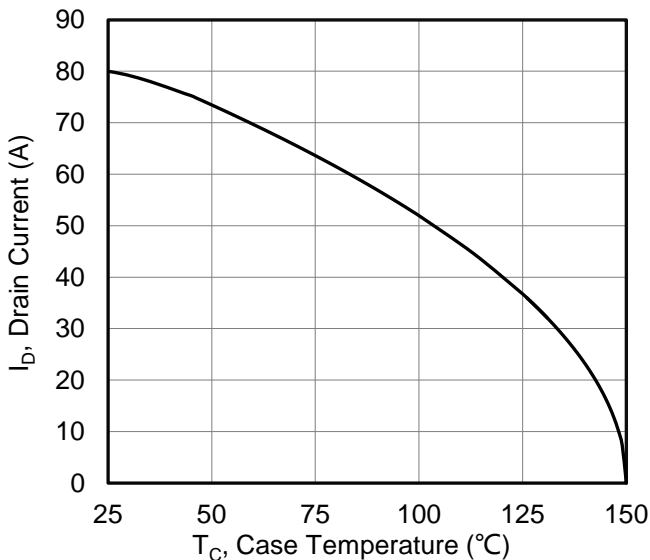

Figure 3. Maximum Continuous Drain Current vs Case Temperature

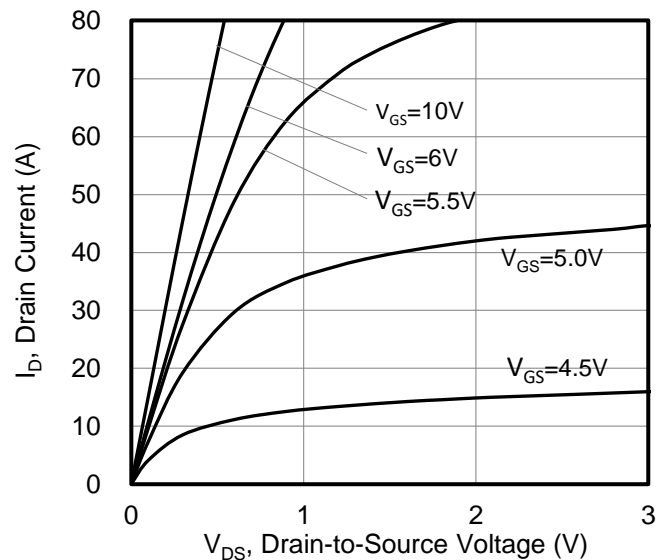

Figure 4. Typical output Characteristics

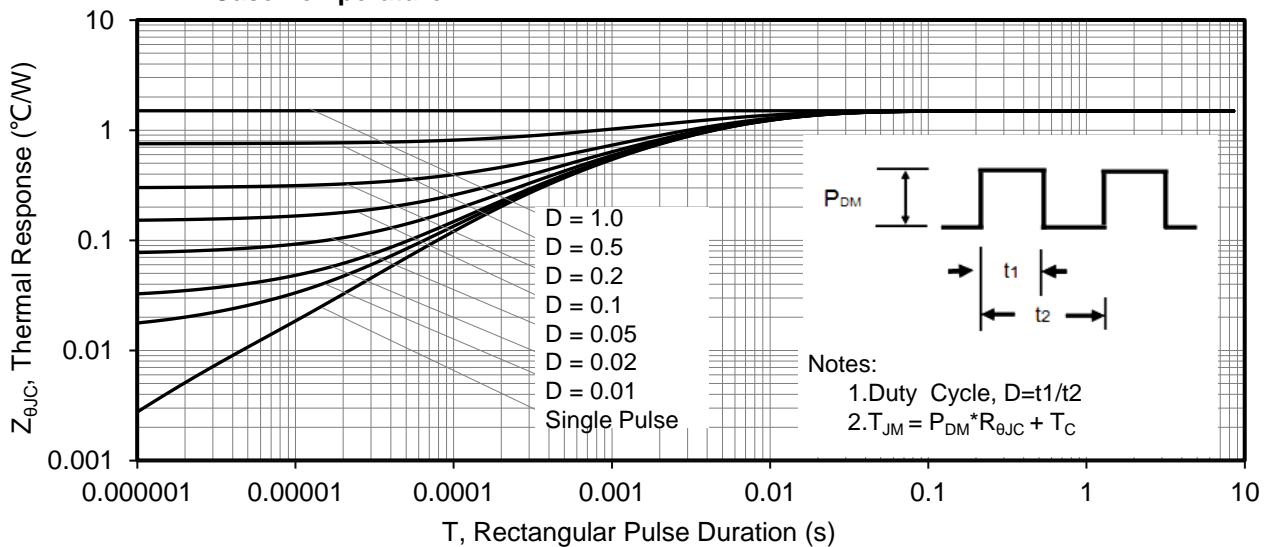

Figure 5. Maximum Effective Thermal Impedance, Junction to Case

Typical Characteristics $T_J = 25^\circ\text{C}$, unless otherwise noted

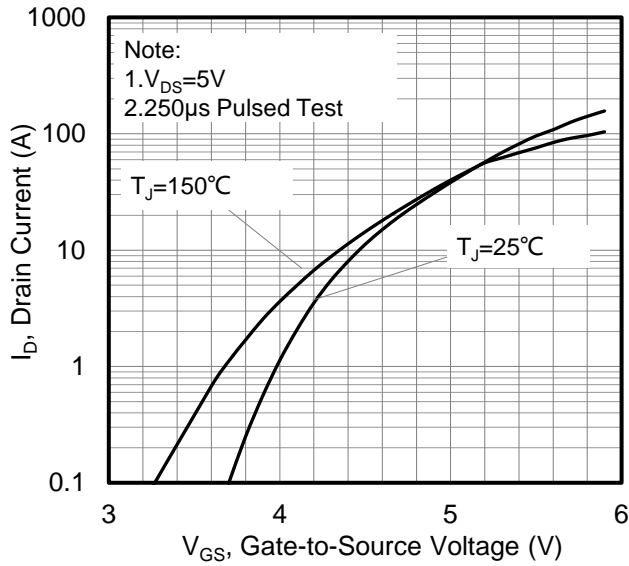

Figure 6. Typical Transfer Characteristics

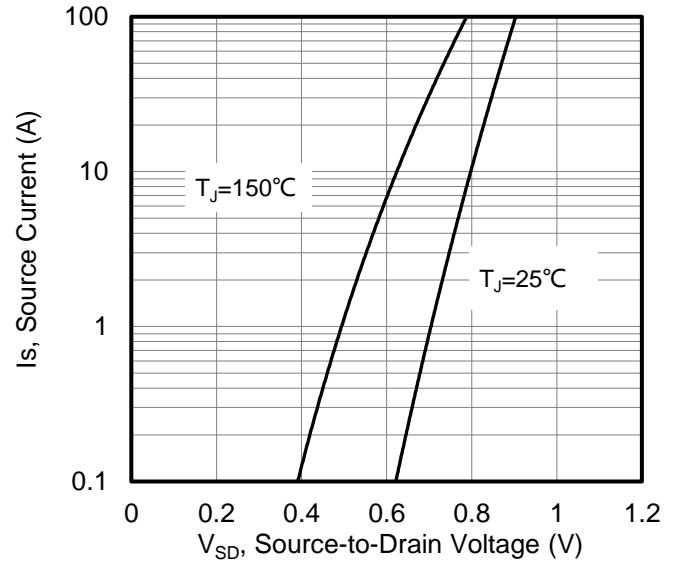

Figure 7. Typical Body Diode Transfer Characteristics

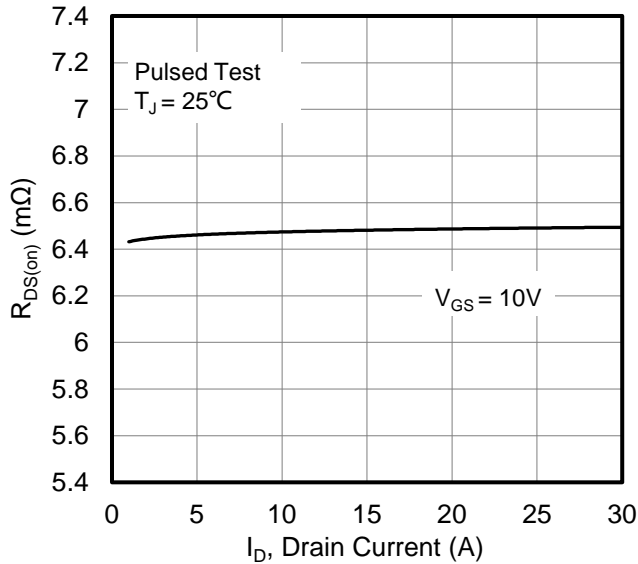

Figure 8. Drain-to-Source On Resistance vs Drain Current

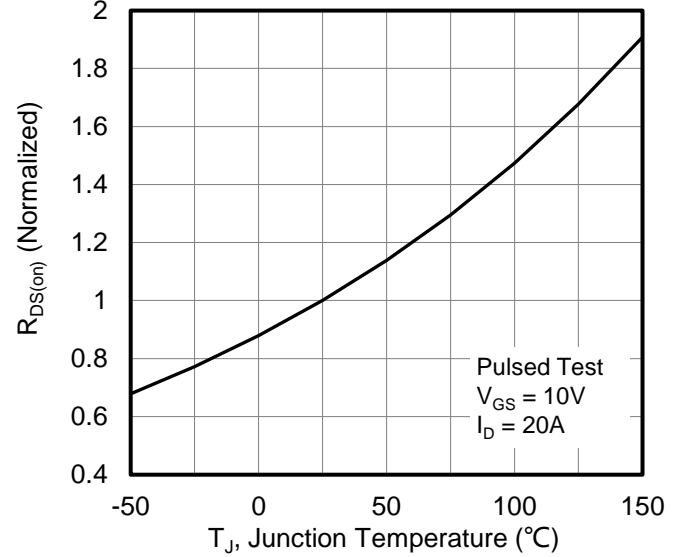

Figure 9. Normalized On Resistance vs Junction Temperature

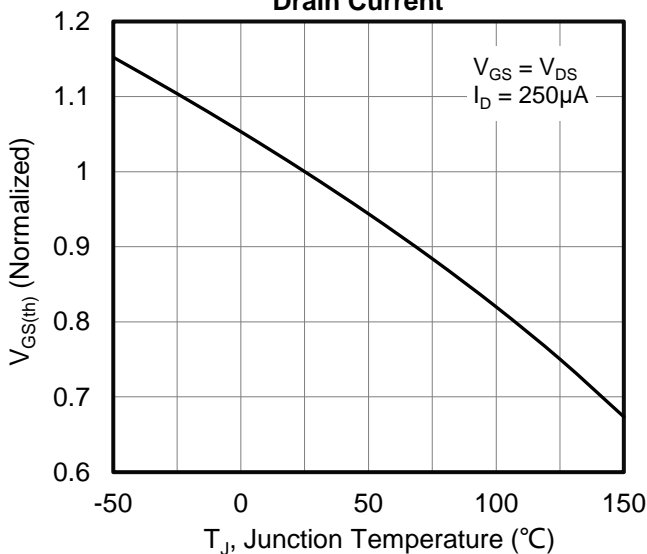

Figure 10. Normalized Threshold Voltage vs Junction Temperature

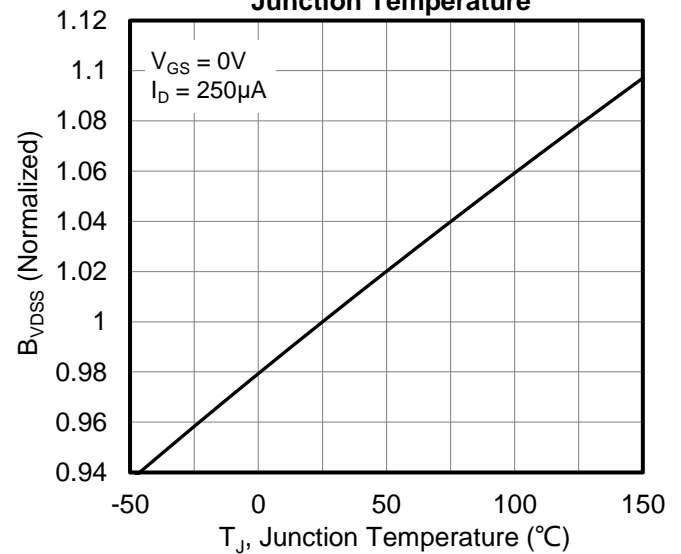

Figure 11. Normalized Breakdown Voltage vs Junction Temperature

Typical Characteristics $T_J = 25^\circ\text{C}$, unless otherwise noted

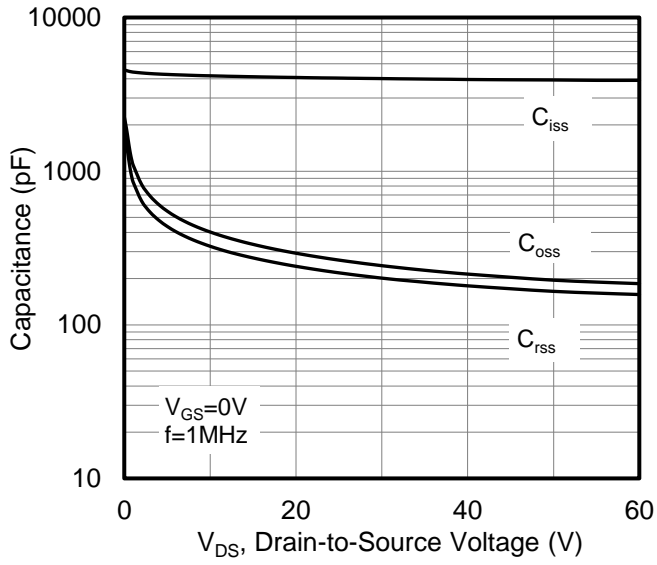

Figure 12. Capacitance Characteristics

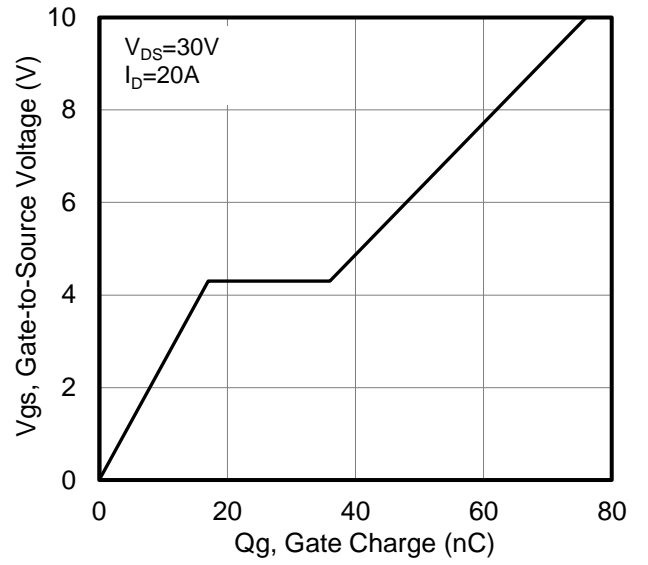

Figure 13. Typical Gate Charge vs Gate to Source Voltage

Figure A: Gate Charge Test Circuit and Waveform

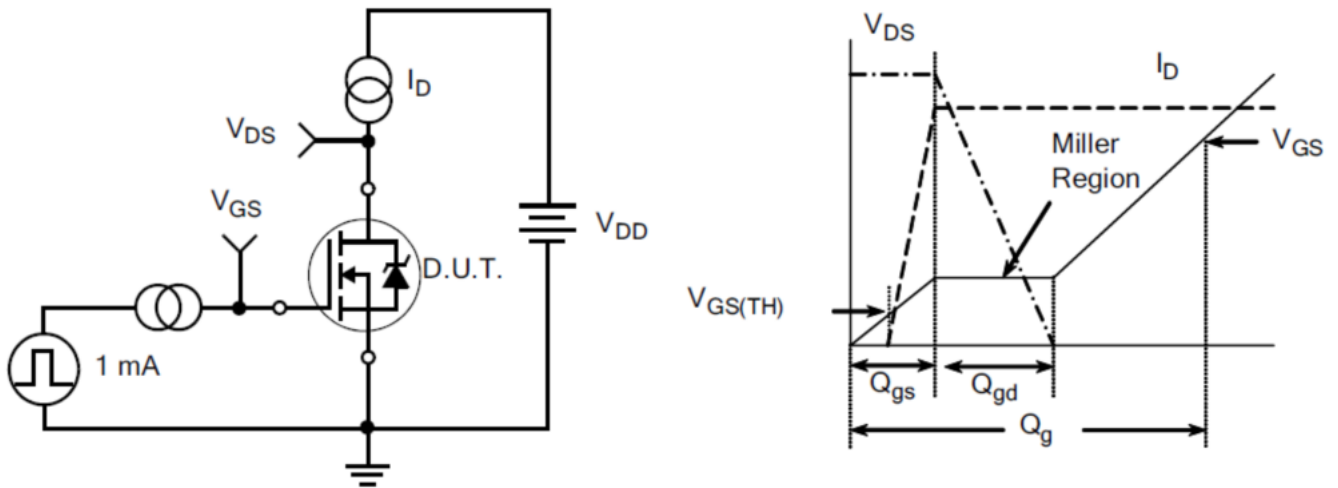

Figure B: Resistive Switching Test Circuit and Waveform

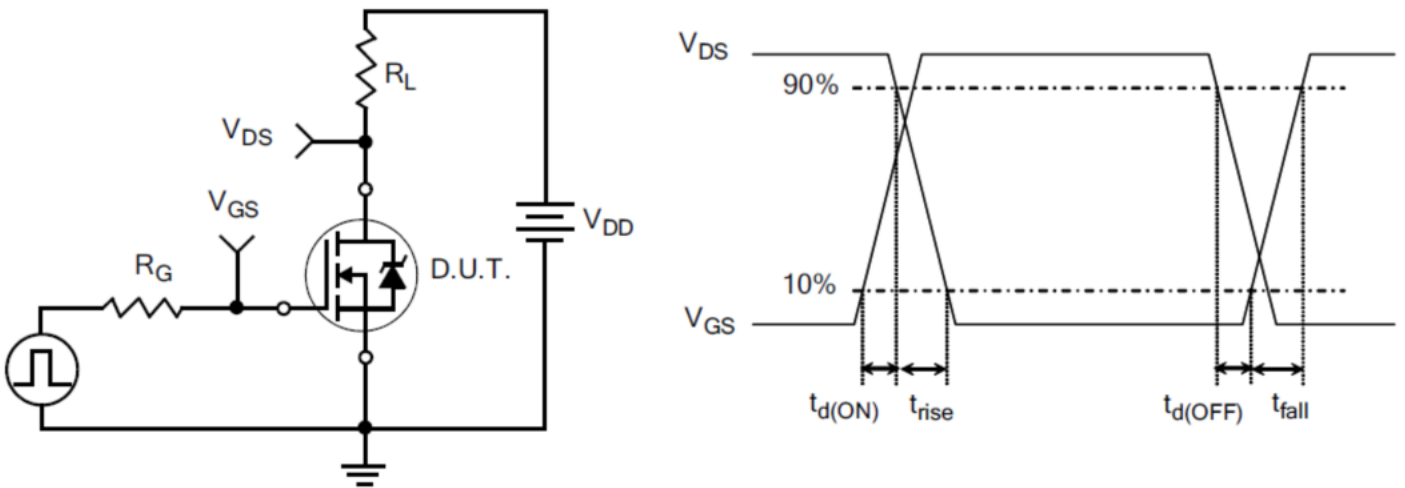
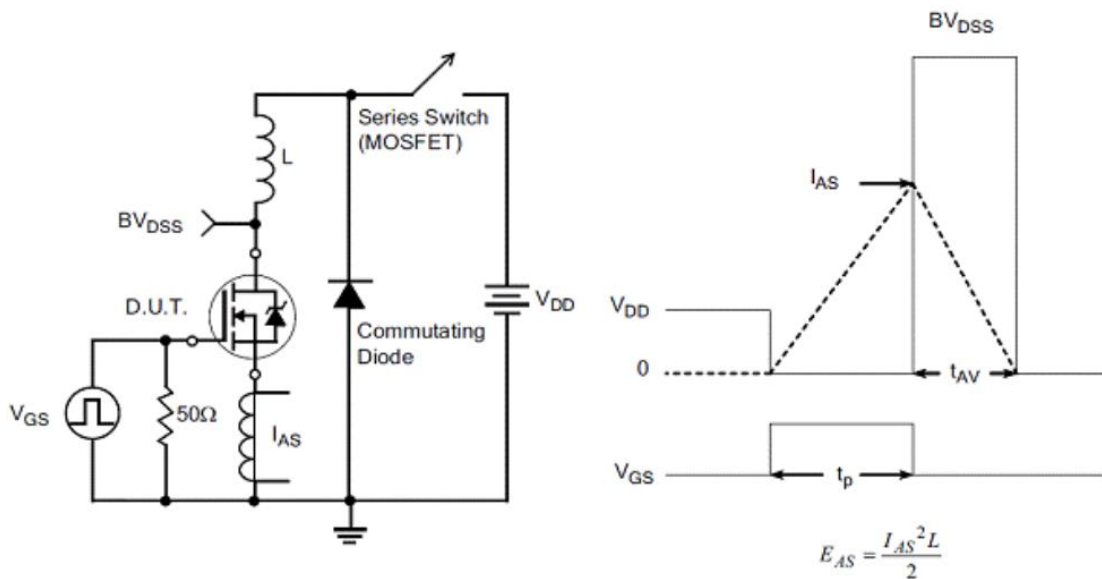
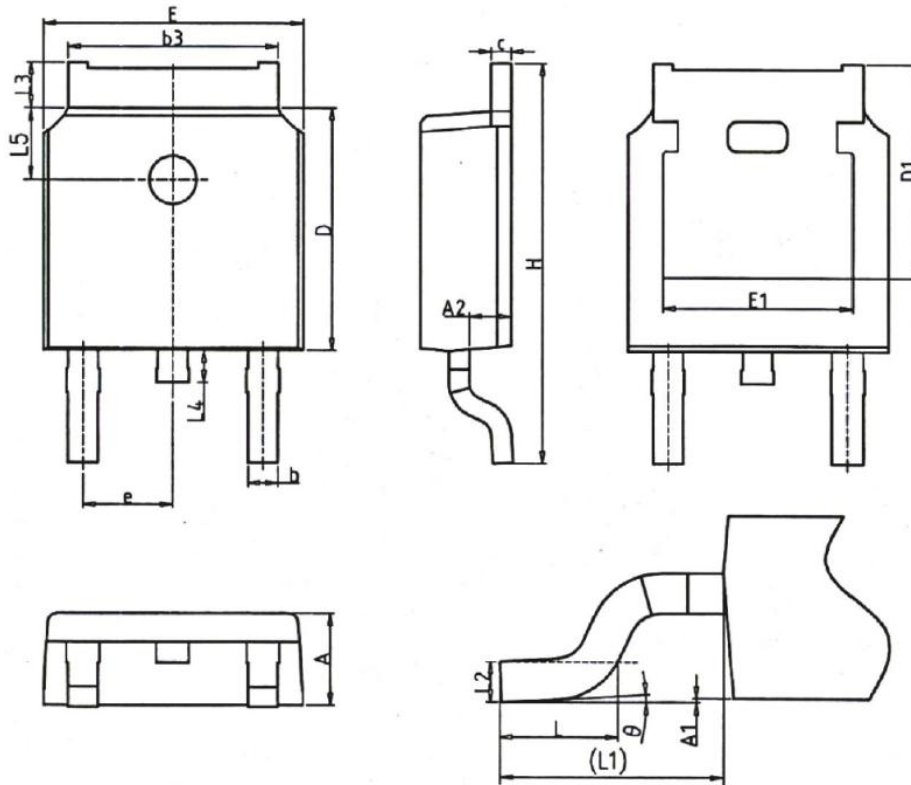

Figure C: Unclamped Inductive Switching Test Circuit and Waveform



Package Information : TO-252



COMMON DIMENSIONS						
SYMBOL	MM			INCH		
	MIN	NOM	MAX	MIN	NOM	MAX
A	2.20	2.30	2.38	0.087	0.091	0.094
A1	0.00		0.20	0.000		0.008
A2	0.97	1.07	1.17	0.038	0.042	0.046
b	0.68	0.78	0.90	0.027	0.031	0.035
b3	5.20	5.33	5.46	0.205	0.210	0.215
c	0.43	0.53	0.61	0.017	0.021	0.024
D	5.98	6.10	6.22	0.235	0.240	0.245
D1	5.30REF			0.209REF		
E	6.40	6.60	6.73	0.252	0.260	0.265
E1	4.63	-	-	0.182	-	-
e	2.286BSC			0.090BSC		
H	9.40	10.10	10.50	0.370	0.398	0.413
L	1.38	1.50	1.75	0.054	0.059	0.069
L1	2.90REF			0.114REF		
L2	0.51BSC			0.020BSC		
L3	0.88		1.28	0.035		0.050
L4	0.50		1.00	0.020		0.039
L5	1.65	1.80	1.95	0.065	0.071	0.077
θ	0°		8°	0°		8°